

# GMX120-3

On/Off, Floating Point, Non-Spring Return, 100 to 240 VAC



Technical Data	GMX120-3
Power supply	100 to 240 VAC, 50/60 Hz (nominal) 85 to 265 VAC, 50/60 Hz (tolerance)
Power consumption	4 W (2 W)
Transformer sizing	7 VA (Class 2 power source)
Electrical connection	18 GA appliance rated cable 1/2" conduit connector protected NEMA 2 (IP54) 3 ft [1m] 10 ft [3m] 16 ft [5m]
Overload protection	electronic throughout 0 to 95° rotation
Control	on/off, floating point
Input impedance	600 Ω
Angle of rotation	max. 95°, adjustable with mechanical stop
Torque	360 in-lb [40 Nm]
Direction of rotation	reversible with  switch
Position indication	reflective visual indicator (snap-on)
Manual override	external push button
Running time	150 seconds, constant independent of load
Humidity	5 to 95% RH non condensing (EN 60730-1)
Ambient temperature	-22°F to 122°F [-30°C to 50°C]
Storage temperature	-40°F to 176°F [-40°C to 80°C]
Housing	NEMA 2, IP54, UL enclosure type 2
Housing material	UL94-5VA
Agency listings†	cULus acc. to UL 60730-1A/-2-14, CAN/CSA E60730-1:02, CE acc. to 2004/108/EEC and 2006/95/EC
Noise level	<45dB(A)
Servicing	maintenance free
Quality standard	ISO 9001
Weight	3.4 lbs [1.55 kg]

†Rated Impulse Voltage 2.5kV, Type of action 1, Control Pollution Degree 3.

Torque min. 360 in-lb for control of damper surfaces up to 90 sq ft.

## Application

For on/off and floating point control of dampers in HVAC systems. Actuator sizing should be done in accordance with the damper manufacturer's specifications.

The actuator is mounted directly to a damper shaft up to 1.05" in diameter by means of its universal clamp. A crank arm and several mounting brackets are available for applications where the actuator cannot be direct coupled to the damper shaft.

## Operation

The actuator is not provided with and does not require any limit switches, but is electronically protected against overload. The anti-rotation strap supplied with the actuator will prevent lateral movement.

The GMX series provides 95° of rotation and a visual indicator indicates position of the actuator. When reaching the damper or actuator end position, the actuator automatically stops. The gears can be manually disengaged with a button on the actuator cover.

The GMX120-3 actuators use a sensorless brushless DC motor, which is controlled by an Application Specific Integrated Circuit (ASIC). The ASIC monitors and controls the actuator's rotation and provides a digital rotation sensing (DRS) function to prevent damage to the actuator in a stall condition. Power consumption is reduced in holding mode.

Add-on auxiliary switches or feedback potentiometers are easily fastened directly onto the actuator body for signaling and switching functions.

## Dimensions (Inches [mm])

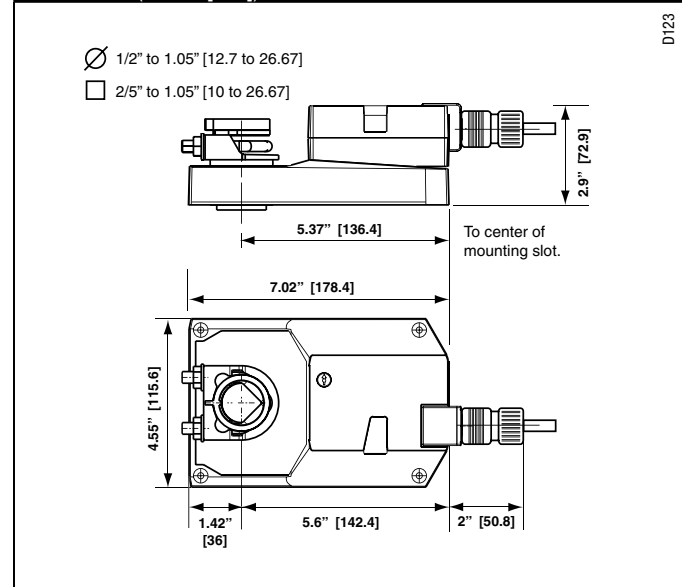

M40024 - 05/10 - Subject to change. © Belimo Aircontrols (USA), Inc.

Accessories	
K-GM20	1/2"-1.05 [12.7 to 26.67 mm] Shaft Clamp
ZG-102	Multiple Actuator Mounting Bracket
Z-GMA	GM to GM Retrofit Mounting Bracket
ZG-GMA	Crank arm Adaptor Kit
ZG-JSA (-1, 2, 3)	Jackshaft Adaptors for Hollow Jackshafts
ZS-100	Weather Shield - Steel
ZS-150	Weather Shield - Polycarbonate
ZS-260	Explosion Proof Housing
ZS-300 (-1) (-5)	NEMA 4X Housing
Tool-07	13 mm Wrench
S1A, S2A	Auxiliary Switch (es)
P370	Shaft Mount Auxiliary Switch
P...A	Feedback Potentiometers

**NOTE:** When using GMX120-3 actuators, only use accessories listed on this page.

### Typical Specification

Floating point, on/off control damper actuators shall be electronic direct-coupled type, which require no crank arm and linkage and be capable of direct mounting to a shaft up to 1.05" diameter. Actuators shall have brushless DC motor technology and be protected from overload at all angles of rotation. Actuators shall have reversing switch and manual override on the cover. Run time shall be constant and independent of torque. Actuators shall be cULus listed, have a 5-year warranty, and be manufactured under ISO 9001 International Quality Control Standards. Actuators shall be as manufactured by Belimo.

### Wiring Diagrams

#### ✂️ INSTALLATION NOTES

1 Provide overload protection and disconnect as required.

2 **CAUTION Equipment Damage!**  
Actuators may be connected in parallel.  
Power consumption and input impedance must be observed.

#### 📄 APPLICATION NOTES

◆ Meets cULus requirements without the need of an electrical ground connection.

⚠️ **WARNING Live Electrical Components!**  
During installation, testing, servicing and troubleshooting of this product, it may be necessary to work with live electrical components. Have a qualified licensed electrician or other individual who has been properly trained in handling live electrical components perform these tasks. Failure to follow all electrical safety precautions when exposed to live electrical components could result in death or serious injury.

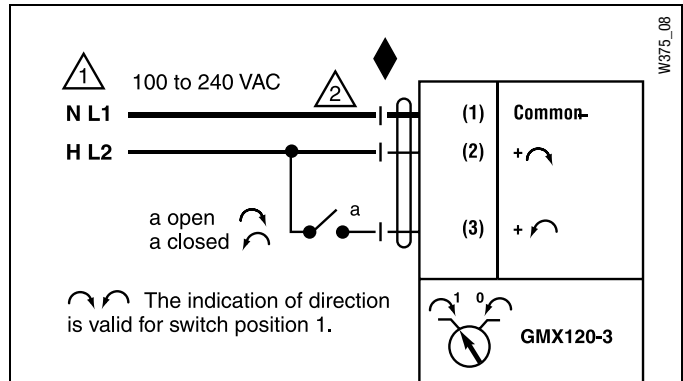

#### On/Off control

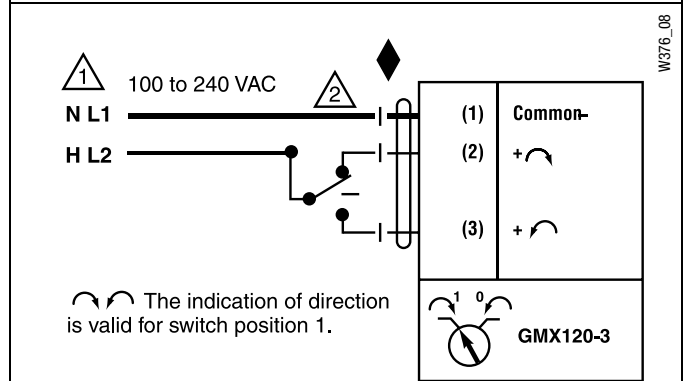

#### Floating Point or On/Off control